



ES-QRJ128

Air Purifier



STERILIZATION



Features

Air Purifier is an purification equipment, which is widely used in hospital , small clinic, laboratory, office, meeting room and house etc. It can protect your life and your health through filtering dust, germ and virus in the air.

Advantage:

1. Low noise.
2. LCD display
3. Remote control.
4. Adjustable air velocity.
5. Thorough sterilizing with UV lamp.
6. Mobile Type, Wall Hanging Type, Suction Ceiling Type.

Model	ES-QRJ128
External Size(W*D*H)	900*120*1500 mm
Filter	Primary Filter, HEPA filter
HEPA Filter	99.99% efficiency at 0.3 μ m
UV Lamp	Germicidal UV lamp, Emission of 253.7 nanometers for most efficient decontamination
Optimal Space	$\leq 20\text{m}^2$
Noise	$\leq 58\text{dB}$
Consumption	240W
Adjustable Air Speed	3 levels
Power Supply	AC220V $\pm 10\%$, 50/60Hz; 110V $\pm 10\%$, 60Hz
Cleanness at Outlet	Class 100
Gross Weight	78kg
Package Size(W*D*H)	1800*440*1050mm

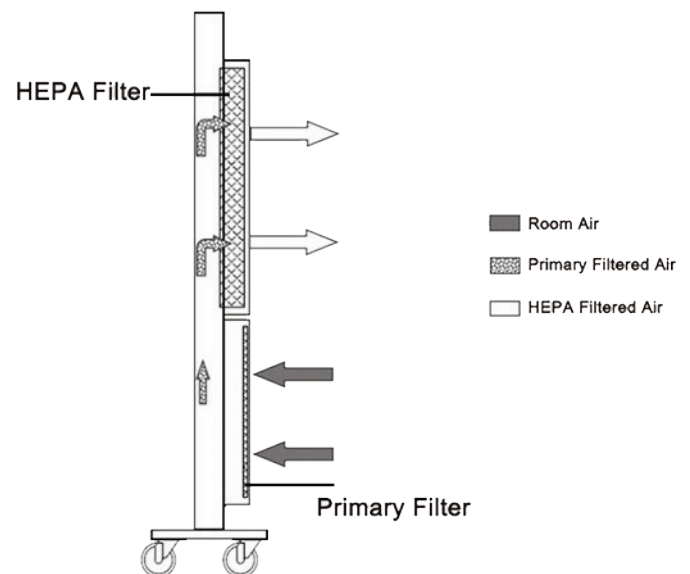
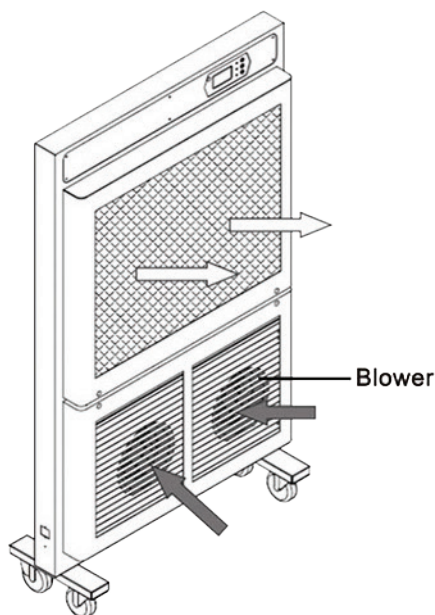

ESSE3 srl, Via Garibaldi 30
14022 Castelnuovo D.B. (AT)
Tel +39 011 99 27 706
Fax +39 011 99 27 506
e-mail esse3@chierinet.it
web: www.esse3.dreamgest.com

